

MFJ

Compact IntelliTuner™ Automatic Antenna Tuner

Model MFJ-928



INSTRUCTION MANUAL

CAUTION: Read All Instructions Before Operating Equipment

MFJ ENTERPRISES, INC.

300 Industrial Park Road
Starkville, MS 39759 USA
Tel: 662-323-5869 Fax: 662-323-6551

Contents

THE BASICS

| | |
|---|----|
| Introduction..... | 1 |
| Features..... | 2 |
| Specifications..... | 2 |
| Fast Start..... | 3 |
| Front Panel..... | 4 |
| SWR LED..... | 4 |
| TUNE LED..... | 4 |
| TUNE Button..... | 4 |
| Automatic/Semi-Automatic Tuning Mode..... | 4 |
| ANT Button..... | 5 |
| POWER Button..... | 5 |
| Back Panel..... | 6 |
| Power..... | 6 |
| Radio Interface..... | 6 |
| Transmitter..... | 9 |
| Antenna 2..... | 9 |
| Antenna 1..... | 9 |
| Ground..... | 9 |
| Wire..... | 9 |
| Installation..... | 10 |

MISCELLANEOUS

| | |
|--|----|
| Antenna Memory..... | 11 |
| <i>IntelliTune</i> [™] Algorithm..... | 11 |
| LC Limits..... | 11 |
| Morse Code and Beeps..... | 12 |
| Foldback Circuit..... | 12 |
| Grounding Hints..... | 13 |
| Antenna System Hints..... | 13 |
| Location..... | 13 |
| Matching Problems..... | 13 |

APPENDICES

| | |
|-----------------------------------|----|
| Resetting the Tuner..... | 15 |
| Factory Defaults..... | 15 |
| Delete Entire Antenna Memory..... | 16 |
| Delete Antenna Memory Bank..... | 16 |
| Total Reset..... | 16 |
| Self Test..... | 17 |
| Power-Down Circuit Test..... | 18 |

| | |
|-------------------------------------|----|
| Relay Test | 18 |
| Frequency Counter Calibration | 19 |
| SWR Bridge Calibration | 19 |
| In Case of Difficulty | 20 |
| Technical Assistance..... | 21 |
| List of Accessories..... | 21 |
| Circuit Block Diagram..... | 22 |

FIGURES

| | |
|--|----|
| Figure 1. Installation Block Diagram..... | 3 |
| Figure 2. MFJ-928 Front Panel | 4 |
| Figure 3. Button Action | 5 |
| Figure 4. MFJ-928 Back Panel | 6 |
| Figure 5. Rado Interface Connector..... | 6 |
| Figure 6. Alinco Interface Cable..... | 7 |
| Figure 7. Icom Interface Cable | 8 |
| Figure 8. Kenwood Interface Cable | 8 |
| Figure 9. Yaesu Interface Cable (FT-100, FT-817, FT-857, FT-897) | 8 |
| Figure 10. Yaesu Interface Cable (FT-847)..... | 9 |
| Figure 11. Power-On Operations | 15 |
| Figure 12. MFJ-928 Circuit Block Diagram..... | 22 |

TABLES

| | |
|----------------------------------|----|
| Table 1. Jumper JP2 Setting..... | 7 |
| Table 2. Memory Resolution | 11 |
| Table 3. Tuner Beeps | 12 |
| Table 4. Failure Messages..... | 17 |

The Basics

Introduction

The MFJ-928 *IntelliTuner*[™] lets you rapidly tune any antenna automatically: unbalanced or single-wire. MFJ's exclusive *InstantRecall*[™], *IntelliTune*[™] and *AdaptiveSearch*[™] algorithms give you fast automatic tuning with more than 20,000 non-volatile *VirtualAntenna*[™] memories. Each of the two antennas has four banks of memory; each memory bank has over 2500 non-volatile memories for tuner settings.

The tuner includes a highly efficient switching L-network with wide matching capability, 1.8 to 30 MHz coverage, a radio interface port, and heavy-duty 10 amp/1000 volt relays. It is rated at 200 watts SSB/CW.

A maximum of 256 values of inductance and 256 values of capacitance are available. With the capacitance switched between the input and output side, this provides a total of 131,072 L/C tuning combinations. The nominal tuning ranges are 0 to 24 μ H and 0 to 3900 pF.

All MFJ *IntelliTuners*[™] learn and remember. When you transmit, they automatically adjust for minimum SWR and remember the frequency and tuner settings, safely stored in non-volatile memory. The next time you operate on that frequency (or close to it) and antenna, these tuner settings are instantly restored and you're ready to operate in milliseconds. Each of two antenna selections has four banks of memory, which can learn and remember more than 2500 frequencies and tuner settings per bank.

When you key your transmitter, MFJ's *InstantRecall*[™] checks its memory to see if you have operated that frequency before. If so, tuning is instantaneous and you're ready to operate. If not, MFJ's *IntelliTune*[™] algorithm (based on MFJ's famous SWR Analyzer technology) kicks in. It measures the complex impedance of your antenna. Next, it calculates the components it needs and instantly snaps them in. Finally, it fine-tunes to minimize SWR, and you're ready to operate--all in a fraction of a second.

If the antenna impedance is not within the tuner's measurement range, MFJ's *AdaptiveSearch*[™] algorithm goes into action. Frequency is measured and relevant components values are determined. Only those values are searched for fast tuning. If it still cannot find a match, the search is performed again using a different search pattern.

All MFJ's *IntelliTuners*[™] support radio tuner interfaces that are compatible with Alinco EDX-2 tuner, Icom AH-3 and AH-4 tuners, Kenwood AT-300 tuner, Yaesu FC-30 tuner, and certain Yaesu radios with CAT system. Optional interface cables MFJ-5114A (for Alinco), MFJ-5114I (for Icom), MFJ-5114K (for Kenwood), and MFJ-5114Y, MFJ-5114Y2 and MFJ-5124Y3 (for Yaesu) are available from MFJ Enterprises, Inc.

The tuners enter a "sleep" mode when idle and when no transmit signal is present, turning off the microprocessor clock to avoid the generation of spurious signals.

Features

- Automatically matches antennas from 6 to 1600 ohms impedance (SWR up to 32:1)
- Handles 200 watts SSB/CW
- Tune in less than 15 seconds, usually less than 5 seconds
- Over 20,000 non-volatile memories for tuner settings
- Four memory banks per antenna with over 2500 memories per bank
- Highly efficient switching L-network matching circuit
- 1.8 to 30 MHz continuous frequency coverage
- Audio SWR meter
- Built-in frequency counter
- Built-in radio interface circuitry for compatible radios
- Built-in bias tee
- Two SO-239 coax fed antenna connectors
- Connector for random wire or single wire antennas

Specifications

- Impedance matching range: 6 to 1600 ohms
- SWR matching range: up to 8:1 for < 50 ohms and up to 32:1 for > 50 ohms
- Minimum power for tuning: 2 watts
- Maximum power while tuning: 100 watts with foldback, 20 watts without foldback
- RF power limit: 200 watts SSB/CW
- Frequency range: 1.8 to 30 MHz continuous coverage
- Frequency counter accuracy: ± 1 kHz across HF bands
- Frequency counter range: up to 50 MHz
- Capacitance range: 0 to 3961 pF nominal (256 values)
- Inductance range: 0 to 24.86 μ H nominal (256 values)
- Relay rating: 10 amp 1000 volts
- Relay electrical life: 100,000 operations
- Relay mechanical life: 10 million operations
- Memory endurance: 1 million erase/write cycles
- Memory data retention: > 200 years
- Power requirements: 12 - 15 volts DC, 2.1 \times 5.5 mm coaxial plug, center pin positive
- Current consumption: 750 milli-amp or less
- Dimensions (approx.): 6.5 \times 2.8 \times 7.5 in. (165 \times 71 \times 191 mm) (width/height/depth)
not including connectors
- Weight (approx.): 2.3 lb. (1.04 kg)

† Specifications and design are subject to change without notice.

Fast Start

WARNING

- **Never operate the tuner with its cover removed. Contact with the components inside the tuner while transmitting will result in painful RF burns.**
- **Locate the tuner so that the rear terminals are *not accessible* during operation. The single wire connection may have high voltage while transmitting.**
- **Disconnect all antennas from the tuner during lightning storms.**
- **Always tune with low power (about 10 watts). Apply maximum power only after tuning up.**
- **Never exceed tuner specifications.**
- **Do not transmit with a high SWR for extended periods of time.**

1. Connect the MFJ-928 to a 12-15 VDC voltage source capable of supplying at least 750 milli-amps.
2. Connect your transmitter to the TRANSMITTER connector using a 50-ohm coaxial cable.
3. Connect your coax-fed antenna to the ANTENNA 1 connector using a 50-ohm coaxial cable, or connect your random wire to the WIRE binding post.
4. Connect your ground connection to the GROUND post.
5. Press the [POWER] button to turn on the MFJ-928 tuner.
6. Press the [ANT] button momentarily until there is one beep. One beep indicates that antenna 1 is selected.
7. Key your transmitter to output a carrier of 10 watts CW, FM or AM.
8. Press and hold the [TUNE] button on the MFJ-928 for one second to start the automatic tuning process. When completed, check to ensure an SWR of 2.0 or less before increasing RF power.
9. You are ready to transmit.

Note: During the automatic tuning process, the tuner will make some noise. These are the relays switching at a very fast pace and it is normal operation. Do not be alarmed.

Note: When the tuner power is OFF, the tuner is in bypass mode and RF from the transmitter goes directly to the antenna (ANTENNA 1) with no matching. When the tuner power is ON, pressing [TUNE] quickly places the tuner in bypass mode (zero inductance and zero capacitance) and indicates by one beep.

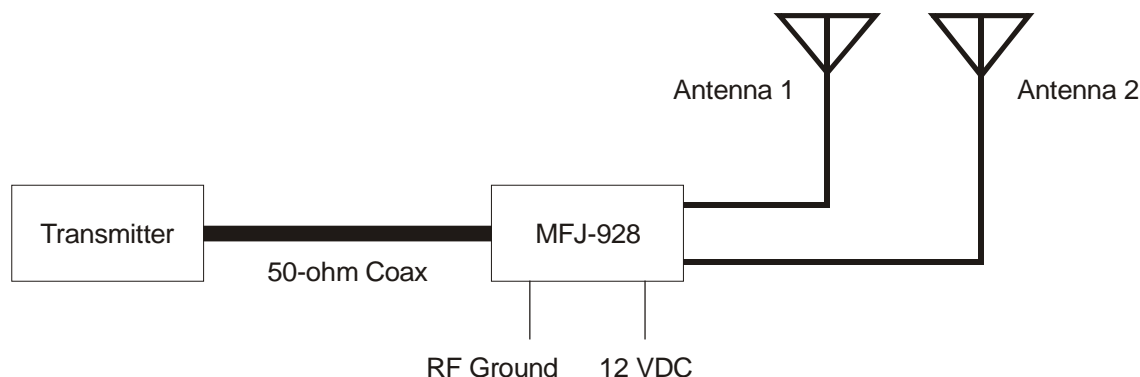

Figure 1. Installation Block Diagram.

Front Panel

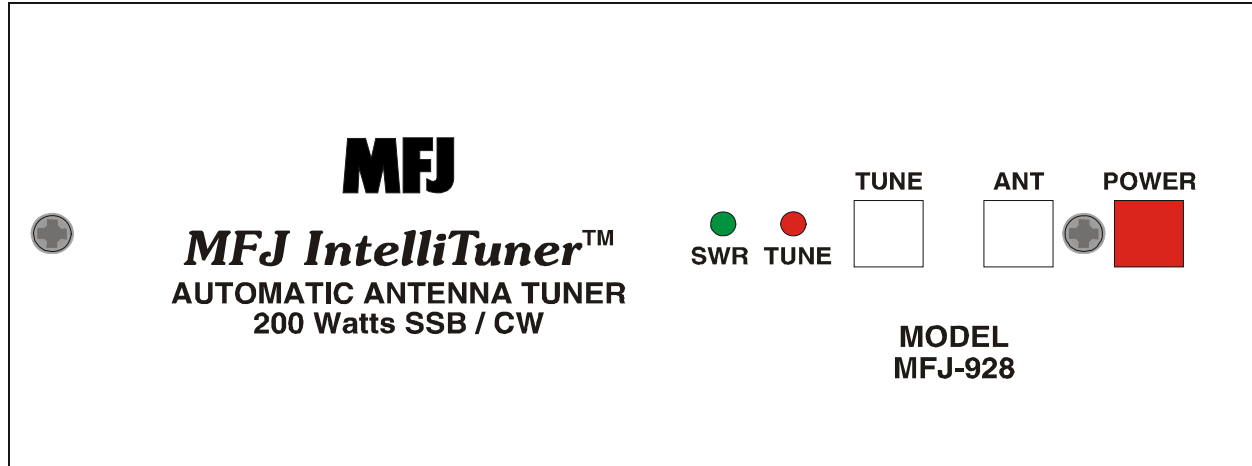

Figure 2. MFJ-928 Front Panel.

- **SWR LED:** A green LED that illuminates when the SWR is 1.5 or less.
- **TUNE LED:** A red LED that illuminates when the automatic tuning is in progress.
- **TUNE Button:** Has three different functions based on the length of time you press and hold it before releasing. Press [TUNE] quickly (less than 0.5 second) to bypass the tuner. One beep indicates bypass mode, where RF from the transmitter goes directly to the antenna with no matching. A second quick press toggles the tuner back to its last L/C setting, and the tuner responds with two beeps.

Press and hold [TUNE] for 0.5 to 2 seconds to start the automatic tuning process. The transmitter must be keyed first with at least two watts of power. When the SWR is already below the target SWR of 1.5, pressing [TUNE] will fine-tune the match for a lower SWR, if possible. When the automatic tuning is completed, a series of beeps indicates the tuned SWR where one beep indicates SWR of 1.5 or less, two beeps indicate SWR of 1.6 to 2.0, three beeps indicate SWR of 2.1 to 2.5, and four beeps indicate SWR of 2.6 to 3.0. For SWR above 3.0, “SWR” (di-di-dit di-dah-dah di-dah-dit) will be sent on CW.

“*StickyTune*” allows for one-handed tuning operation. Normal tuning requires keying the transmitter with one hand and using the other hand to push the [TUNE] button to start the tuning process. To toggle the *StickyTune* mode on and off, press and hold the [TUNE] button for two seconds. One beep indicates on and two beeps indicate off. When enabled, the tuning process starts automatically when the transmitter is keyed with at least two watts of power regardless of the SWR. This works in both automatic and semi-automatic modes.

Automatic/Semi-Automatic Tuning Mode

Pressing [TUNE] and [ANT] simultaneously toggles between automatic and semi-automatic tuning mode. One beep indicates automatic mode and two beeps indicate semi-automatic mode. In automatic mode, the tuning routine is automatically started when at least two watts of power is applied and the SWR is greater than 2.5. In semi-automatic mode, the tuning routine starts only when the [TUNE] button is pressed for 0.5 to 2 seconds.

Note: During the tuning process, the tuner will make some noise. These are the relays switching at a very fast pace and it is normal operation. Do not be alarmed.

- **ANT Button:** Has two different functions based on the length of time you press and hold it before releasing. Press [ANT] quickly (less than one second) to select the antenna to tune. Press button to toggle between Antenna 1 and Antenna 2. One beep indicates Antenna 1 and two beeps indicate Antenna 2. A single-wire antenna is, by default, Antenna 1.

Press and hold [ANT] for one second to cycle among the four memory banks of the current antenna. The selected bank is indicated by a series of short beeps, where one beep indicates bank A, two beeps indicate bank B, three beeps indicate bank C, four beeps indicate bank D, and five beeps indicate antenna memory is OFF. See “Antenna Memory” on page 11.

Pressing the [ANT] button will switch the antenna or bank *only* when there is no RF power; also, the tuner setting for the selected antenna and bank, if available, is instantly restored from memory when enabled.

- **POWER Button:** Used to turn the power on and off. When the power is off, the tuner is placed in bypass mode and Antenna 1 is selected. When turning on the power, the tuner automatically restores all previous settings and displays the target SWR on the main screen.

WARNING: Do not turn the power on and off rapidly, otherwise the tuning setting memory can be corrupted and the unit will have to be reset to factory defaults.

Note: When the tuner power is OFF, the tuner is in bypass mode and RF from the transmitter goes directly to the antenna (ANTENNA 1) with no matching.

BUTTON ACTION

Press **POWER** in to turn power on, out to turn power off.

Press **TUNE** less than 0.5 second to toggle bypass mode; press and hold for 0.5 to 2 seconds to start the tuning process; press and hold for more than two seconds to toggle the StickyTune on and off.

Press **ANT** less than one second to toggle between antenna 1 and antenna 2; press and hold for more than one second to cycle the 4 antenna memory banks.

Press **TUNE** + **ANT** to toggle between automatic and semi-automatic mode.

Figure 3. Button Action.

Back Panel

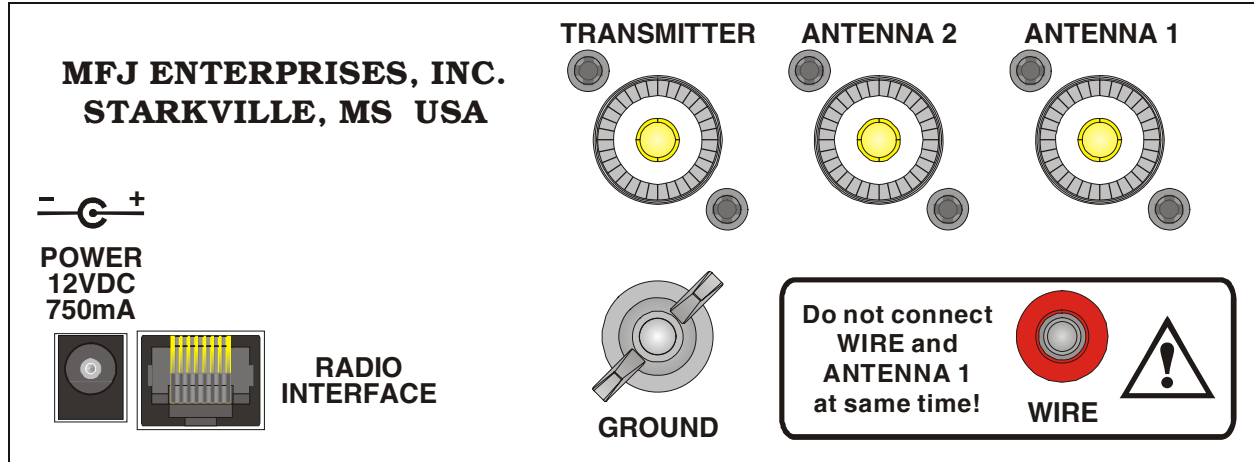

Figure 4. MFJ-928 Back Panel.

- **Power:** This jack accepts a standard 2.1 × 5.5 mm coaxial plug with positive center and negative sleeve. The tuner requires 12 volts DC at up to 750 milli-amps. The use of a regulated supply is not mandatory but is recommended for best performance. An optional 12 volts DC 1.5 amp power supply, the MFJ-1316, is available from MFJ Enterprises, Inc.

WARNING: Do not apply voltages greater than 18 volts to this unit, or permanent damage to the unit may result.

Note: When the tuner power is OFF, the tuner is in bypass mode and RF from the transmitter goes directly to the antenna (ANTENNA 1) with no matching.

- **Radio Interface:** An 8-pin modular (RJ-45) connector for connecting to the tuner interface connector of compatible radios. Most radios provide +13.8 VDC power through its tuner interface connector. If separate power supplies are used to power the MFJ-928, the MFJ-928 should be powered on first (both LEDs blink once) and then turn on the radio, so the radio knows an external tuner is attached. The radio will disable its internal tuner, if it has one, and use the external tuner.

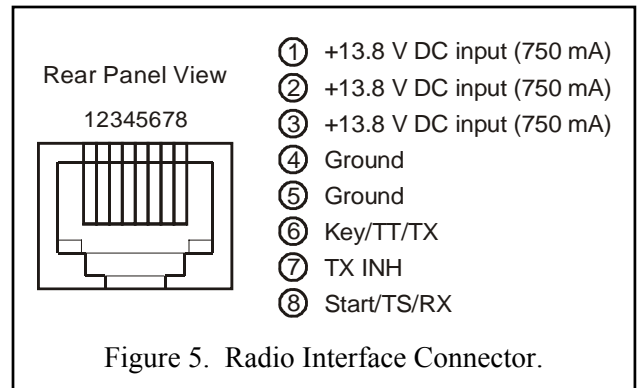

Figure 5. Radio Interface Connector.

The Radio Interface works with radios that are compatible with Alinco EDX-2, Icom AH-3 and AH-4, Kenwood AT-300, and certain Yaesu radios with CAT system. When connected to a compatible radio, simply press the [TUNER] or [AT] button on the radio; for certain Yaesu, press the [TUNE] button *on the tuner* to start the automatic tuning process. The radio will automatically switch to CW mode (AM for Yaesu), transmit a 10-watt carrier, and start the tuning process. Once the automatic tuning is completed, the radio will return to its previous mode and power setting.

WARNING: Make sure the +13.8 volts connection on the radio's tuner port is capable of supplying at least 750 mA of current, since the MFJ-928 uses up to 750 mA.

Jumper JP2, located behind the front panel circuit board, selects the radio to be connected to the Radio Interface connector. Set this jumper to the "I" position to interface with radios that are compatible with the Alinco EDX-2 tuner, Icom AH-3 and AH-4 tuners (also for interfacing to the MFJ-5124Y3). Set the jumper to the "K" position to interface with radios that are compatible with Kenwood AT-300 tuner. Set the jumper to the "Y" position to interface with Yaesu FT-100; "1" position to interface with Yaesu FT-817, FT-857 or FT-897; and "2" position to interface with Yaesu FT-847. If no cable is connected to the Radio Interface connector, set the jumper to the "0" position to disable the interface. Default is "0".

| Jumper JP2 | To Interface | Using |
|------------|--|--------------------------------------|
| 0 | No Radio Interface | -- |
| I | Alinco Icom Yaesu TUNER (FT-857/897) | MFJ-5114A MFJ-5114I MFJ-5124Y3 |
| K | Kenwood | MFJ-5114K |
| Y | Yaesu CAT (FT-100) | MFJ-5114Y |
| 1 | Yaesu CAT (FT-817/857/897) | MFJ-5114Y |
| 2 | Yaesu CAT (FT-847) | MFJ-5114Y2 |
| 3 | Reserved | -- |
| 4 | Reserved | -- |

Table 1. Jumper JP2 Setting.

The MFJ-5114A interface cable provides power and control between an Alinco radio and the MFJ automatic tuner. Supported Alinco radios are DX-70, DX-77, and any Alinco radio that supports the Alinco EDX-2 tuner.

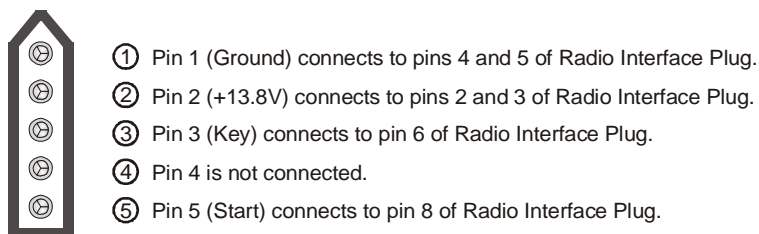

Figure 6. Alinco Interface Cable.

The MFJ-5114I interface cable provides power and control between an Icom radio and the MFJ automatic tuner. Supported Icom radios are IC-706, IC-707, IC-718, IC-725, IC-728, IC-736, IC-738, IC-746, IC-756, IC-765, IC-775, and any Icom radio that supports the Icom AH-3 or AH-4 tuner. Push and hold the radio's [TUNER] button for two seconds to start the tuning process. Push [TUNER] quickly to bypass the tuner.

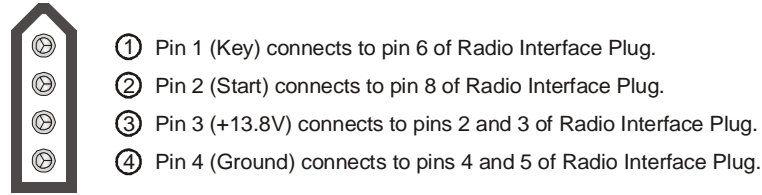

Figure 7. Icom Interface Cable.

The MFJ-5114K interface provides power and control between a Kenwood radio and the MFJ automatic tuner. Supported Kenwood radios are TS-50S, TS-450S, TS-480HX, TS-570S, TS-690S, TS-850S, TS-870S, TS-2000, and any Kenwood radio that supports the Kenwood AT-300 tuner. Push and hold the radio's [AT TUNE] button for one second to start the tuning process. Push the [AT TUNE] quickly to bypass the tuner or to cancel tuning in progress.

Note: *The TS-480HX will automatically reduce its TX power to 100 watts maximum (25 watts AM) when the radio interface is used.*

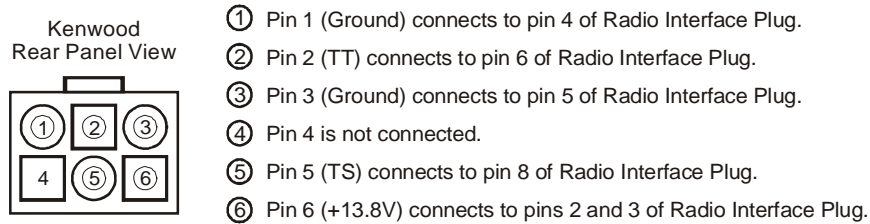

Figure 8. Kenwood Interface Cable.

The MFJ-5114Y interface provides power and control between a Yaesu radio and the MFJ automatic tuner. Supported Yaesu radios are FT-100, FT-817, FT-857, FT-897, and any Yaesu radio with compatible CAT system. Push the [TUNE] button *on the tuner* for 0.5 to 2 seconds to start the tuning process.

Important: *The +13.8 volts connection on the FT-817's CAT port cannot supply 750 mA of current needed by the MFJ-928. So remove jumper JP1 located in front of the Radio Interface jack, and use a separate DC power supply to power the MFJ-928.*

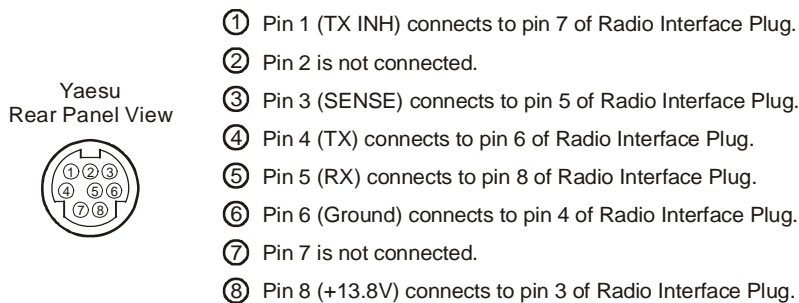

Figure 9. Yaesu Interface Cable (FT-100, FT-817, FT-857, FT-897).

The MFJ-5114Y2 interface provides control between a Yaesu radio and the MFJ automatic tuner. Supported Yaesu radios are FT-847 and any Yaesu radio with compatible CAT system. Push the [TUNE] button *on the tuner* for 0.5 to 2 seconds to start the tuning process.

Note: *The CAT port on the FT-847 does not have a +13.8 volts connection, so a separate DC power supply must be used to power the MFJ-928.*

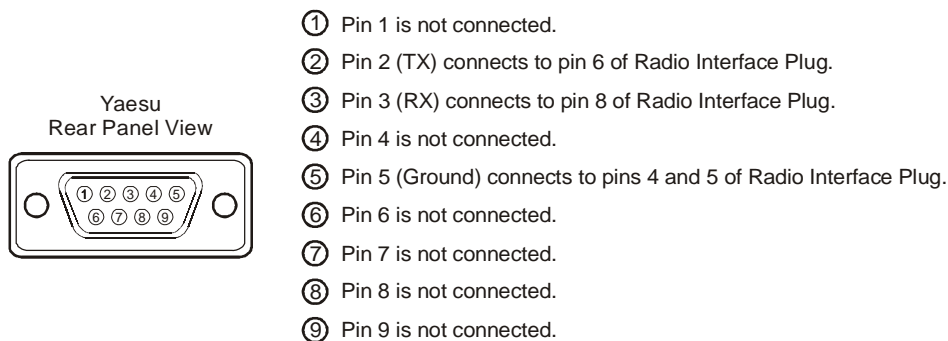

Figure 10. Yaesu Interface Cable (FT-847).

The MFJ-5124Y3 (yes, the MFJ-5124Y3) interface provides power and control between a Yaesu radio and the MFJ automatic tuner. Supported Yaesu radios are FT-857, FT-897, and any Yaesu radio that supports the Yaesu FC-30 tuner. Make sure to set jumper JP2 to the “I” position to use the MFJ-5124Y3. Press and hold in the [A](TUNE) key *on the radio* for one second to initiate automatic tuning.

- **Transmitter:** SO-239 connector for coax cable from transmitter or transceiver. There is a bias tee connected to this connector so 12 volts DC can be sent down the coax to power the tuner for remote operation. An optional bias tee DC power injector, the MFJ-4116, is available from MFJ Enterprises, Inc.
- **Antenna 2:** SO-239 connector for coax cable from antenna.
- **Antenna 1:** SO-239 connector for coax cable from antenna. Notice the ANTENNA 1 connector is internally connected to the WIRE binding post.

Note: *To use the ANTENNA 1 connector, make sure to remove the wire antenna, if any, from the WIRE binding post.*

- **Ground:** Wing-nut terminal for RF ground wire connection.
- **Wire:** Binding post for connecting single wire antennas. Notice the WIRE binding post is internally connected to the ANTENNA 1 connector.

Note: *To use the WIRE binding post, make sure to remove the antenna, if any, from the ANTENNA 1 connector.*

Installation

WARNING

- **Never operate the tuner with its cover removed. Contact with the components inside the tuner while transmitting will result in painful RF burns.**
- **Locate the tuner so that the rear terminals are *not accessible* during operation. The single wire connection may have high voltage while transmitting.**
- **Disconnect all antennas from the tuner during lightning storms.**
- **Always tune with low power (about 10 watts). Apply maximum power only after tuning up.**
- **Never exceed tuner specifications.**
- **Do not transmit with a high SWR for extended periods of time.**

1. Place the tuner in a convenient location at the operating position. With a random wire, the feed through insulators may have high RF voltages. These voltages can cause serious RF burns if the terminals are touched when transmitting. **Be sure to locate the tuner so these terminals cannot accidentally be contacted during operation.**
 2. Install the tuner between the transmitter and the antenna. Use a 50-ohm coaxial cable (such as RG-58) to connect the transmitter (or amplifier) to the connector marked TRANSMITTER on the rear of the tuner. See Figure 1 on page 3.
 3. Connect the antenna(s) to the tuner as follows:
 - Coaxial feedlines to the SO-239 connectors labeled ANTENNA 1 and/or ANTENNA 2.
 - Random wire or single wire line antennas should be connected to the WIRE binding post on the back of the tuner. Note the back panel warning: **Do not connect WIRE and ANTENNA 1 at same time!** When a single wire antenna is connected it “becomes” ANTENNA 1.
- Note:** Route all single and random wire antennas safely to prevent RF burn hazard.
4. A GROUND post is provided for an RF ground connection. See “Grounding Hints” on page 13.
 5. Connect a 12 to 15 VDC power source to the input jack labeled POWER.

Miscellaneous

Antenna Memory

The “memory resolution” is the width of frequency spectrum that the tuner recognizes as being the same as a tuned frequency already in memory. The memory resolution is approximately 0.1 percent of the lower frequency of each amateur band. For example, the memory resolution on the 40-meter band (7000 to 7300 kHz) is 7 kHz; if the tuner has memorized a setting for 7050 kHz, it will automatically call up this setting for any frequency from 7047 to 7053 kHz. Memory resolution is smaller at lower frequency to accommodate the higher antenna Q and larger at higher frequency where the antenna Q is lower. The memory resolutions for the HF amateur bands 160 through 10 meters are:

| Meter | Frequency Range (kHz) | Memory Resolution (kHz) |
|-------|---|-------------------------|
| 160 | 1800 – 2000 | 2 |
| 75/80 | 3500 – 4000 | 4 |
| 60 | 5330.5, 5346.5, 5366.5, 5371.5 and 5403.5 | 5 memory locations |
| 40 | 7000 – 7300 | 7 |
| 30 | 10100 – 10150 | 10 |
| 20 | 14000 – 14350 | 14 |
| 17 | 18068 – 18168 | 18 |
| 15 | 21000 – 21450 | 21 |
| 12 | 24890 – 24990 | 25 |
| 10 | 28000 – 29700 | 28 |

Table 2. Memory Resolution.

The memory resolution for non-amateur frequency bands between 160 and 10 meters is approximately 0.2 percent of the lower frequency of each band. There are over 2500 memory locations for each memory bank, and each of the two antennas has four memory banks (A-D). Tuner settings are stored in memory separately for Antenna 1 and Antenna 2 (settings for single-wire antenna are stored as Antenna 1). This provides memory for up to eight different antennas. See “ANT Button” on page 5. Defaults are memory banks 1A and 2A ON.

IntelliTune™ Algorithm

When the tuner cannot find an appropriate setting in its memory, it begins its calculation function. It measures the complex impedance of the antenna (load) at the transmitting frequency, then it calculates the LC components needed for a match. Then it fine-tunes the components for minimum SWR. If for any reason the tuner cannot calculate the load impedance, it proceeds to yet another method of calculation.

LC Limits

The upper limits of inductance (L) and capacitance (C) are factory-limited according to frequency and maximum power rating; i.e., higher frequencies need less inductance and less capacitance when the L-network is properly tuned. These limits are built into the MFJ-928 to prevent matching of extreme load impedance outside the tuner’s specification, which may result in excess voltage and/or current across the tuner’s components.

Morse Code and Beeps

If not enough power is applied for tuning (less than two watts), “QRO” (dah-dah-di-dah di-dah-dit dah-dah-dah) will be sent on CW. Increasing the input power above two watts ends this message.

When input power is too high, the tuner enters a self-protection mode. The tuner will not allow any of its relays to change. This feature is to prevent damage to your tuner.

If too much power is applied when tuning, the tuner will cease the tuning routine and send “QRP” (dah-dah-di-dah di-dah-dit di-dah-dah-dit) on CW. This occurs when the forward power exceeds 75 watts and the SWR is greater than 3.0, or when the forward power exceeds 125 watts regardless of the SWR.

If more than 200 watts is applied to the tuner, the tuner will go into bypass mode and send “QRT” (dah-dah-di-dah di-dah-dit dah) on CW.

If the tuning process is activated under these conditions, the tuner will not start the tuning. It will send the appropriate code on CW.

The following table shows the various tuner beeps:

| Function | Indicates By One Beep | | | Indicates By Two Beeps | | By Pressing |
|-------------------|----------------------------------|-----------------------|-----------------------|--------------------------|---------------------|--------------------------------|
| Antenna | 1 | | | 2 | | [ANT] < 1 second |
| Memory Bank | Bank A (1 beep) | Bank B (2 beeps) | Bank C (3 beeps) | Bank D (4 beeps) | Off (5 beeps) | [ANT] > 1 second |
| Bypass Toggle | Bypass Mode (L = 0 and C = 0) | | | Restore Last L/C Setting | | [TUNE] < 0.5 sec. |
| Tuned SWR | SWR ≤1.5 (1 beep) | SWR ≤2.0 (2 beeps) | SWR ≤2.5 (3 beeps) | SWR ≤3.0 (4 beeps) | SWR >3.0 (“SWR”) | [TUNE] for 0.5 to 2 seconds |
| <i>StickyTune</i> | On | | | Off | | [TUNE] > 2 seconds |
| Tuning Mode | Automatic | | | Semi-Automatic | | [TUNE] + [ANT] |

Table 3. Tuner Beeps.

Foldback Circuit

Modern transceivers with solid-state finals usually have a foldback circuit to protect the final transistors from high SWR, which can damage or destroy them. A foldback circuit detects the SWR during transmit and reduces the output power as the SWR rises above a preset threshold, usually 2:1. The higher the SWR the lower the power is set to prevent damage.

If your transceiver has a foldback circuit, you can simply key down and tune at any power level from 2 to 100 watts. If your transceiver does not have a foldback circuit, you must manually set the power level to 20 watts or less for tuning. At higher power levels, the reflected power occurred during tuning can damage your transceiver and causes component arcing which can damage the relays in the tuner.

Check your transceiver owner's manual to see if yours has a foldback circuit.

Grounding Hints

To minimize RFI, single wire feedlines (such as used with Windom or longwire antennas) should be kept away from other wiring. Radiation will be minimized if the single wire feeder runs parallel and reasonably close to the wire that connects the tuner to the outdoor ground. The antenna feed wire should be adequately insulated to prevent arcing or accidental contact.

CAUTION

For operator safety, a good outside earth ground or water pipe ground should always be installed and connected to the case of the MFJ-928. Make certain the safety ground also connects to the transmitter and other station accessories. A wing-nut post marked GROUND is provided for ground connections.

For safety, please use good DC and RF grounds. It is particularly important to have a good RF ground when using a single wire feeder. When using a single wire feeder, the tuner needs something to "push" against in order to force current into the single wire feedline. If a good RF ground is not available, RF will usually find its way back into the power line (RFI), transmitter audio circuits (RF feedback), or the operator (RF burns).

Metal water pipes and ground rods provide good DC and AC safety grounds, but they are often inadequate for RF grounding because they are single conductors. Ground rods by themselves are almost useless for dependable RF grounding.

RF grounds work much better when "spread out" over a large area, especially when they employ multiple connections directly to the equipment ground point. Metal water pipes, heating ducts, and fences may work (especially if they are connected together with multiple wires), but the best RF grounds are radial systems or multi-wire counterpoises. Radials and counterpoises provide large, low resistance surfaces for RF energy.

RF and lightning travel on the surface of conductors. Braided or woven conductors have high surface resistance to lightning and RF. Ground leads for RF and lightning should have wide smooth surfaces. Avoid the use of woven or braided conductors in RF and lightning grounds unless the lead needs to be flexible.

Antenna System Hints

Location

For the best performance, an end-fed longwire wire antenna should be at least one quarter-wavelength long at the operating frequency. Horizontal dipole antennas should be at least a half-wavelength long and located as high and clear as possible. While good RF grounds help the signal in almost any transmitting installation, it is extremely important to have good RF grounds with long wire or other Marconi-style antennas.

Matching Problems

Most matching problems occur when the antenna system presents an extremely high impedance to the tuner. When the antenna impedance is much lower than the feedline impedance, an *odd quarter-*

wavelength feedline converts the low antenna impedance to a very high impedance at the tuner. A similar problem occurs if the antenna has an extremely high impedance and the transmission line is a multiple of a half-wavelength. The half-wavelength line *repeats* the very high antenna impedance at the tuner. Incorrect feedline and antenna lengths can make an otherwise perfect antenna system very difficult or impossible to tune.

One example where this problem occurs is on 80 meters when an odd quarter-wave (60 to 70 feet) open wire line is used to feed a half-wave (100 to 140 feet) dipole. The odd quarter-wave line transforms the dipole's low impedance to over three thousand ohms at the tuner. This is because the mismatched feedline is an *odd multiple* of 1/4 wavelength long. The line *inverts* (or teeter-totters) the antenna impedance.

A problem also occurs on 40 meters with this same antenna example. The feedline is now a multiple of a half-wave (60 to 70 feet) and connects to a full-wave high impedance antenna (100 to 140 feet). The half-wave line repeats the high antenna impedance at the tuner. The antenna system looks like several thousand ohms at the tuner on 40 meters.

This places enormous strain on the balun and the insulation in the tuner, since voltages can reach several thousand volts. This can cause component arcing and heating.

The following suggestions will reduce the difficulty in matching an antenna with a tuner:

- Never center feed a half-wave multi-band antenna with a high impedance feedline that is close to an odd multiple of a quarter-wave long.
- Never center feed a full-wave antenna with a feedline close to a multiple of a half-wave long.
- If this tuner will not "tune" a multi-band antenna, add or subtract 1/8 wave of feedline (for the band that won't tune) and try again.
- Never try to load a G5RV or center fed dipole on a band below the half-wave design frequency. If you want to operate an 80-meter antenna on 160 meters, feed either or both conductors as a longwire against the station ground.

To avoid problems matching or feeding any dipole antenna with high impedance open wire lines, keep the lines around these lengths. [The *worst possible* line lengths are shown in brackets]:

| | | |
|--------------------|---------------------------------------|----------------------------|
| 160 meters dipole: | 35-60, 170-195 or 210-235 feet | [Avoid 130, 260 ft] |
| 80 meters dipole: | 34-40, 90-102 or 160-172 feet | [Avoid 66, 135, 190 ft] |
| 40 meters dipole: | 42-52, 73-83, 112-123 or 145-155 feet | [Avoid 32, 64, 96, 128 ft] |

Some slight trimming or adding of feedline may be necessary to accommodate the higher bands.

WARNING

To avoid problems, a dipole antenna should be a full half-wave on the lowest band. On 160 meters, an 80 or 40 meters antenna fed the normal way will be extremely reactive, with only a few ohms of feedpoint resistance. Trying to load an 80 meters half-wave dipole (or shorter) antenna on 160 meters can be a disaster for both your signal and the tuner. The best way to operate 160 meters with an 80 or 40 meters antenna is to load either or both feedline wires (in parallel) as a longwire. The antenna will act like a "T" antenna worked against station ground.

Appendices

POWER-ON OPERATIONS
(Press and hold buttons while turning on the power.)

Press and hold **TUNE** + **POWER** to start the self test.

Press and hold **TUNE** + **ANT** + **POWER** to delete current antenna memory.

Press and hold **ANT** + **POWER** then press **TUNE** 1 time to reset factory defaults.

Press and hold **ANT** + **POWER** then press **TUNE** 2 times to delete current memory bank.

Press and hold **ANT** + **POWER** then press **TUNE** 3 times to perform total reset.

Press and hold **ANT** + **POWER** then press **TUNE** 4 times to test the power-down circuitry.

Press and hold **ANT** + **POWER** then press **TUNE** 5 times to test the relays.

Press and hold **ANT** + **POWER** then press **TUNE** 6 times to calibrate the frequency counter.

Press and hold **ANT** + **POWER** then press **TUNE** 7 times to calibrate the SWR bridge.

For the **ANT** + **POWER** operations, not pressing **TUNE** or pressing it more than seven times will cancel the operation after idling four seconds, beep two times and then resume normal operation.

Figure 11. Power-On Operations.

Resetting the Tuner

Each time the tuner is powered off, the microprocessor saves all memories and configurations to non-volatile memory ready to be used the next time the unit is turned on again. If the tuner is not working properly, even on initial power on, try resetting to the factory defaults.

Factory Defaults

The unit is shipped with the following default settings:

- Inductance 0 μ H
- Capacitance 0 pF on antenna side
- Antenna 1
- Memory Banks 1A and 2A on †
- Tuning Mode Automatic †

† These settings are stored separately for antennas 1 and 2.

Note: *Resetting to factory defaults does not erase the antenna memories.*

To reset the tuner to these defaults:

1. Turn off the power to the tuner.
2. Press and hold *only* the [ANT] button while turning the power on. Both LEDs will blink until the button is released.
3. Within four seconds of releasing [ANT], press the [TUNE] button once.
4. After releasing [TUNE] for four seconds, beep three times and resume normal operation.

WARNING: If the MFJ-928 is behaving weirdly or acting erratic, try resetting the tuner to factory defaults.

Delete Entire Antenna Memory

To delete an entire antenna memory (all four banks), first select the antenna (1 or 2) that you want to delete. See “ANT Button” on page 5 for details.

1. Turn off the power to the tuner.
2. Press and hold *both* the [TUNE] and [ANT] buttons while turning the power on. It takes approximately three seconds to delete all four memory banks of the current antenna.
3. Beep three times and release the buttons to resume normal operation. Remember that the selected antenna memory will be lost!

Delete Antenna Memory Bank

To delete an antenna memory bank, first select the antenna (1 or 2) and the memory bank (A, B, C or D) that you want to delete. See “ANT Button” on page 5 for details.

1. Turn off the power to the tuner.
2. Press and hold *only* the [ANT] button while turning the power on. Both LEDs will blink until the button is released.
3. Within four seconds of releasing [ANT], press the [TUNE] button two times.
4. After releasing [TUNE] for four seconds, the current memory bank is deleted.
5. Beep three times and resume normal operation. Remember that the selected antenna memory bank will be lost! However, if the memory is off, no memory bank is deleted; then beep two times and resume normal operation.
6. Repeat the above procedure to delete the other memory banks, if desired.

Total Reset

To erase *both* antenna memories (all eight banks) and reset to factory defaults:

1. Turn off the power to the tuner.
2. Press and hold *only* the [ANT] button while turning the power on. Both LEDs will blink until the button is released.
3. Within four seconds of releasing [ANT], press the [TUNE] button three times.
4. After releasing [TUNE] for four seconds, both antenna memories are deleted and factory defaults are reset. The total reset takes approximately six seconds.
5. Beep three times and resume normal operation. Remember that both antenna memories will be lost!

Self Test

A self-test routine will check the functions of the MFJ-928. This routine checks the LEDs, the front-panel buttons, the internal memory, the audio circuitry, and the power-down circuitry. During the self-test, you may stop the test by turning off the unit; however, this should NOT be done during the memory test or the memory could be corrupted. The self-test can be completed in approximately 10 seconds.

Note: *Performing the self-test will reset the unit to its factory default settings.*

Here is the self-test procedure:

1. Turn off the power to the tuner.
2. Unplug the radio interface cable, if one is connected, from the tuner.
3. Press and hold *only* the [TUNE] button while turning the power on.
4. The test begins by blinking the firmware version number via the two front panel LEDs. The green LED blinks first, followed by the red LED. The version number X.Y is represented by the number of times the green LED blinks for X and the number of times the red LED blinks for Y. For example, green LED blinks one time and red LED blinks two times represent firmware version number 1.2. This is also the test of the LEDs.
5. Release the [TUNE] button. The unit then checks for short circuits, power-down detection level, and wakeup circuitry.
6. Press [ANT] button and the green LED should blink once.
7. Press [TUNE] button and the green LED should blink once.
8. The unit then tests its non-volatile memory. Notice this step will reset the unit to its factory default settings.
9. If the unit is okay, a repetitive message “PASS” will be sent as Morse code (di-dah-dah-dit di-dah di-di-dit di-di-dit) and the green LED will blink. If there is a problem, a failure message will be sent repetitively and the red LED will blink.
10. Once you have confirmed that the audio is okay, turn the unit off.
11. Wait one second and turn the unit on again to test the power-down detection circuitry.
12. If the power-down detection circuitry is okay, a repetitive message “PASS” will be sent as Morse code (di-dah-dah-dit di-dah di-di-dit di-di-dit) and the green LED will blink. If there is a problem, message “PD FAIL” will be sent as Morse code repetitively and the red LED will blink.
13. Turn the power off.

| Failure Message | Indicates |
|-----------------|--|
| ANT FAIL | [ANT] button is shorted or improperly connected. |
| TUNE FAIL | [TUNE] button is shorted or improperly connected. |
| MEMORY FAIL | Non-volatile memory circuitry is improperly connected. |
| WAKEUP FAIL | Microprocessor wakeup circuitry problem. |
| PD FAIL | Power-down circuitry problem. |

Table 4. Failure Messages.

Power-Down Circuit Test

When the 12 VDC power to the tuner is turned off, the tuner saves all settings to non-volatile memory. The Power-Down Circuit Test checks the power-down detection circuitry. It is recommended that this test be done immediately after the regular self-test described above.

Note: *The tuner must be reset to factory defaults before performing this test.*

Here is the test procedure:

1. Make sure power to the tuner is off.
2. If the tuner has been reset to factory defaults, skip to step 6; otherwise continue with step 3.
3. Press and hold *only* the [ANT] button while turning the power on. Both LEDs will blink until the button is released.
4. Within four seconds of releasing [ANT], press the [TUNE] button once.
5. After releasing [TUNE] for four seconds, beep three times and turn the power off.
6. Press and hold *only* the [ANT] button while turning the power on. Both LEDs will blink until the button is released.
7. Within four seconds of releasing [ANT], press the [TUNE] button four times.
8. After releasing [TUNE] for four seconds and if the power-down detection circuitry is okay, a repetitive message "PASS" will be sent as Morse code (di-dah-dah-dit di-dah di-di-dit di-di-dit) and the green LED will blink. If there is a problem, message "PD FAIL" will be sent as Morse code repetitively and the red LED will blink.
9. Turn the power off.

Relay Test

WARNING: Turn off the transmitter power or disconnect the transmitter before performing this test; otherwise, damage to the tuner can result.

To test the relays and their control circuitry;

1. Turn off the power to the tuner.
2. Press and hold *only* the [ANT] button while turning the power on. Both LEDs will blink until the button is released.
3. Within four seconds of releasing [ANT], press the [TUNE] button five times.
4. After releasing [TUNE] for four seconds, beep once and the Relay Test routine is initiated.
5. Press the [TUNE] button to engage the relay and the red LED will turn on. Release the [TUNE] button to disengage the relay and the red LED will turn off. Listen for relay clicks.
6. There are 19 relays in the tuner. Press the [ANT] button to test the next relay. The green LED will illuminate until the [ANT] button is released.
7. Repeat Steps 5 and 6 to test all 19 relays (in the order of relay K1 to K19).
8. After releasing [ANT] on the 19th relay, beep three times and resume normal operation.

Frequency Counter Calibration

To calibrate the frequency counter, you will need a transmitter, a 50-ohm dummy load, two 50-ohm SO-239 coax cables, a Phillips screwdriver, and a tuning tool or small flat blade screwdriver.

WARNING: Do not touch anything inside the tuner during operation! Serious, painful RF burns can result.

WARNING: Never operate the MFJ-928 with its cover removed; dangerous voltages and currents can be present during operation. Never exceed tuner specifications.

1. Turn off the power to the transmitter and the tuner.
2. Remove the cover from the tuner (10 screws) with a Phillips screwdriver.
3. Connect the 50-ohm dummy load to the ANTENNA 1 connector; connect the transmitter to the TRANSMITTER connector on the tuner.
4. Turn on the power to the transmitter. Set and lock the frequency to *exactly* 29.000 MHz.
5. Press and hold *only* the [ANT] button while turning the power on. Both LEDs will blink until the button is released.
6. Within four seconds of releasing [ANT], press the [TUNE] button six times.
7. After releasing [TUNE] for four seconds, the green LED lights up and the Frequency Counter Calibration is initiated.
8. Key the transmitter to output about 10 watts and adjust trimmer capacitor VC3 (located next to the big integrated circuit on the front side of the front panel circuit board) until both LEDs are lighted up. The green LED lights when the calibration is below 29 MHz, the red LED lights when the calibration is above 29 MHz and both LEDs light up when the calibration equals to 29 MHz.
9. Unkey the transmitter. Turn off the power to the transmitter and the tuner.
10. Secure the cover back onto the tuner.

SWR Bridge Calibration

To calibrate the SWR Bridge, you will need a transmitter capable of 100 watts output, a precise calibrated wattmeter, a 50-ohm dummy load, three 50-ohm SO-239 coax cables, a Phillips screwdriver, a tuning tool or small flat blade screwdriver, and a cross-needle wattmeter (available only at MFJ factory). Therefore, this calibration can only be done at MFJ factory.

WARNING: Do not touch anything inside the tuner during operation! Serious, painful RF burns can result.

WARNING: Never operate the MFJ-928 with its cover removed; dangerous voltages and currents can be present during operation. Never exceed tuner specifications.

1. Turn off the power to the transmitter and the tuner.
2. Remove the cover from the tuner (10 screws) with a Phillips screwdriver.
3. Connect the cross-needle wattmeter to header HD1, located behind the front panel circuit board.
4. Connect the 50-ohm dummy load to the ANTENNA 1 connector; connect the wattmeter between the transmitter and the TRANSMITTER connector on the tuner.
5. Turn on the power to the transmitter. Using a frequency in the middle of the HF band, such as 7.253 MHz, for calibration is recommended.

6. Press and hold *only* the [ANT] button while turning the power on. Both LEDs will blink until the button is released.
7. Within four seconds of releasing [ANT], press the [TUNE] button seven times.
8. After releasing [TUNE] for four seconds, the cross-needle wattmeter shows 100 watts forward and 20 watts reflected and the SWR Bridge Calibration is initiated.
9. Make sure the cross-needle wattmeter reads 100 watts forward and 20 watts reflected. If not, calibrate the cross-needle wattmeter.
10. Press the [TUNE] button and both meter needles drop to 0 watt marks.
11. Key the transmitter to output 100 watts and adjust trimmer capacitor VC1 (located in front of the TRANSMITTER connector) for minimum reflected power. Notice the reflected meter movement is exaggerated for easier calibration.
12. Key the transmitter to output 100 watts and adjust the FWD trimpot VR1 (located next to the RADIO INTERFACE connector) until the forward meter shows 100 watts.
13. Press the [TUNE] button and the reflected meter goes to full scale.
14. Turn off the transmitter and reverse the ANTENNA 1 and TRANSMITTER connections; that is, connect the 50-ohm dummy load to the TRANSMITTER connector and connect the transmitter/wattmeter to the ANTENNA 1 connector.
15. Turn on the transmitter's power.
16. Key the transmitter to output 100 watts and adjust the REF trimpot VR2 (located next to the RADIO INTERFACE connector) until the forward meter (yes, the forward meter) shows 100 watts; the reflected meter is at full scale.
17. Press the [TUNE] button to end calibration.
18. Turn off the power to the transmitter and the tuner.
19. Remove the cross-needle wattmeter from header HD1.
20. Remove the transmitter/wattmeter and the 50-ohm dummy load from the tuner.
21. Secure the cover back onto the tuner.
22. Connect your transmitter to the TRANSMITTER connector and connect your antenna to the appropriate antenna connector on the tuner.

In Case of Difficulty

If the LCD screen is blank, check adjustment of the contrast control. If no audio is present (with audio enabled) adjust the volume control.

If the tuner acts erratic, reset the tuner to factory defaults by pressing both the [TUNE] and [L-UP] buttons while turning the power on.

If the tuner fails to tune, please **double check** all connections and follow the tuning procedures again. Be sure you are using *enough inductance* (through manual adjustment) and *minimum capacitance*.

If the tuner arcs at the rated power levels, please **double check** all connections and follow the tuning procedures again. Ensure you are not exceeding the tuner's rated power handling capability. Be sure you are using the *least amount of inductance* and the *greatest capacitance* possible that still allows matching the load on the operating frequency.

Note: *If the tuner arcs when operating on the 160-meter band, it may be necessary to reduce transmitter output power.*

If you are still unsuccessful, but the tuner does adjust and operate when used with a dummy load or another antenna, please read "Grounding Hints" and "Antenna System Hints" on page 13.

Technical Assistance

If you have any problem with this unit first check the appropriate section of this manual. If the manual does not reference your problem or your problem is not solved by reading the manual, you may call *MFJ Technical Service* at 662-323-0549 or the *MFJ Factory* at 662-323-5869. You will be best helped if you have your unit, manual and all information on your station handy so you can answer any questions the technicians may ask.

You can also send questions by mail to MFJ Enterprises, Inc., 300 Industrial Park Road, Starkville, MS 39759; by facsimile (FAX) to 662-323-6551; or by email to techinfo@mfjenterprises.com. Send a complete description of your problem, an explanation of exactly how you are using your unit, and a complete description of your station. Also include the firmware version number of your unit.

List of Accessories

- **MFJ-1316:** 12 VDC 1.5 amp power supply
- **MFJ-4116:** BiasTee DC power injector
- **MFJ-5114A:** Interface cable for compatible Alinco radios
- **MFJ-5114I:** Interface cable for compatible Icom radios
- **MFJ-5114K:** Interface cable for compatible Kenwood radios
- **MFJ-5114Y:** Interface cable for Yaesu FT-100, FT-817, FT-857 and FT-897 (CAT)
- **MFJ-5114Y2:** Interface cable for Yaesu FT-847 (CAT)
- **MFJ-5124Y3:** Interface cable for Yaesu FT-857 and FT-897 (TUNER)
- **MFJ-5409:** 6 feet long RS-232 cable, female DB-9 to male DB9 connector
- **MFJ-5803:** 3 feet long RG-58 A/U 50-ohm coax cable with a PL-259 connector on each end
- **MFJ-5806:** 6 feet long RG-58 A/U 50-ohm coax cable with a PL-259 connector on each end
- **MFJ-5818:** 18 feet long RG-58 A/U 50-ohm coax cable with a PL-259 connector on each end

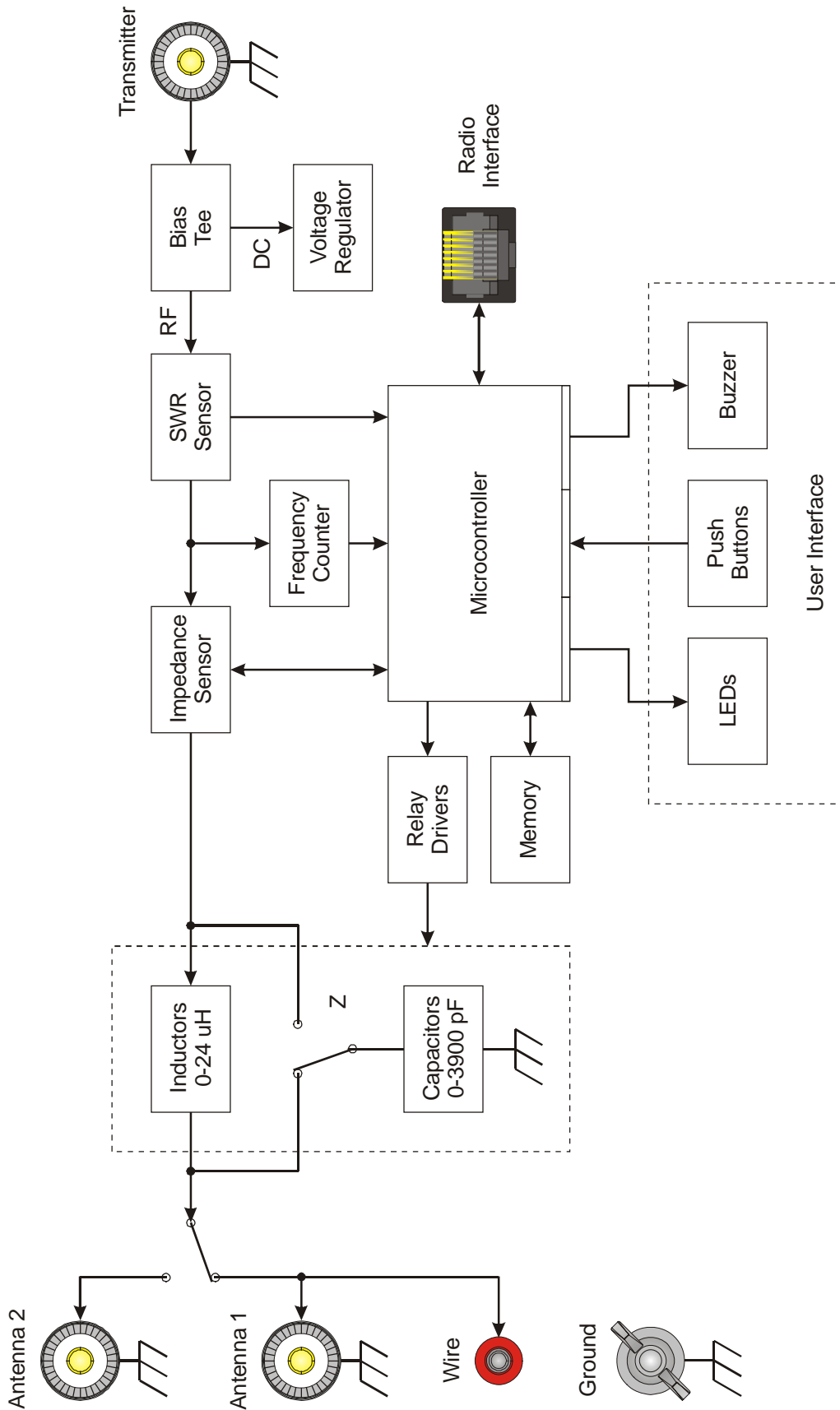

Figure 12. MFJ-928 Circuit Block Diagram.

LIMITED 12 MONTH WARRANTY

MFJ Enterprises, Inc. warrants to the original owner of this product, if manufactured by MFJ Enterprises, Inc. and purchased from an authorized dealer or directly from MFJ Enterprises, Inc. to be free from defects in material and workmanship for a period of 12 months from date of purchase provided the following terms of this warranty are satisfied.

1. The purchaser must retain the dated proof-of-purchase (bill of sale, canceled check, credit card or money order receipt, etc.) describing the product to establish the validity of the warranty claim and submit the original or machine reproduction of such proof of purchase to MFJ Enterprises, Inc. at the time of warranty service. MFJ Enterprises, Inc. shall have the discretion to deny warranty without dated proof-of-purchase. Any evidence of alteration, erasure, or forgery shall be cause to void any and all warranty terms immediately.
2. MFJ Enterprises, Inc. agrees to repair or replace at MFJ's option without charge to the original owner any defective product under warrantee provided the product is returned postage prepaid to MFJ Enterprises, Inc. with a personal check, cashiers check, or money order for **\$7.00** covering postage and handling.
3. This warranty is **NOT** void for owners who attempt to repair defective units. Technical consultation is available by calling the Service Department at 662-323-0549 or the MFJ Factory at 662-323-5869.
4. This warranty does not apply to kits sold by or manufactured by MFJ Enterprises, Inc.
5. Wired and tested PC board products are covered by this warranty provided **only the wired and tested PC board product is returned**. Wired and tested PC boards installed in the owner's cabinet or connected to switches, jacks, or cables, etc. sent to MFJ Enterprises, Inc. will be returned at the owner's expense unrepaired.
6. Under no circumstances is MFJ Enterprises, Inc. liable for consequential damages to person or property by the use of any MFJ products.
7. **Out-of-Warranty Service:** MFJ Enterprises, Inc. will repair any out-of-warranty product provided the unit is shipped prepaid. All repaired units will be shipped COD to the owner. Repair charges will be added to the COD fee unless other arrangements are made.
8. This warranty is given in lieu of any other warranty expressed or implied.
9. MFJ Enterprises, Inc. reserves the right to make changes or improvements in design or manufacture without incurring any obligation to install such changes upon any of the products previously manufactured.
10. All MFJ products to be serviced in-warranty or out-of-warranty should be addressed to:

**MFJ Enterprises, Inc.
300 Industrial Park Road
Starkville, Mississippi 39759 USA**

and must be accompanied by a letter describing the problem in detail along with a copy of your dated proof-of-purchase.

11. This warranty gives you specific rights, and you may also have other rights which vary from state to state.



MFJ ENTERPRISES, INC.
300 Industrial Park Road
Starkville, MS 39759

MFJ-928 Manual
Version 0A
Printed In U.S.A. 10/2005